

REVISIONS				
P.	LTN	DESCRIPTION	DATE	APVD
A		INITIAL RELEASED	25OCT2017	Z.L
A1		ECR-20-007092	2JUN2020	AX
A2		ECR-20-008480	15JUN2020	J.L

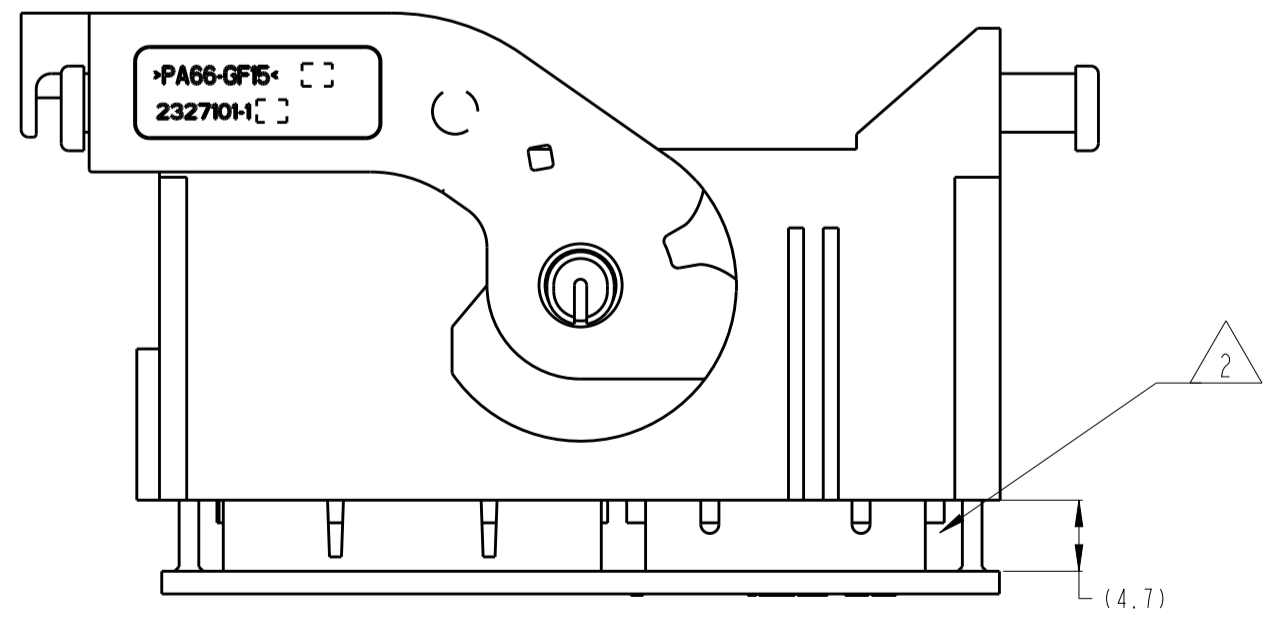

SHIPMENT CONFIGURATION

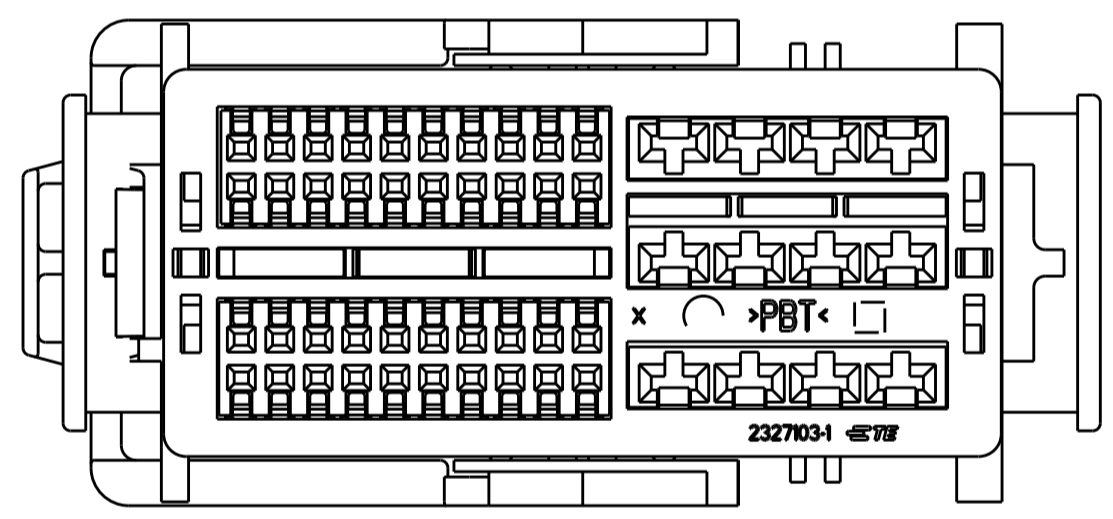
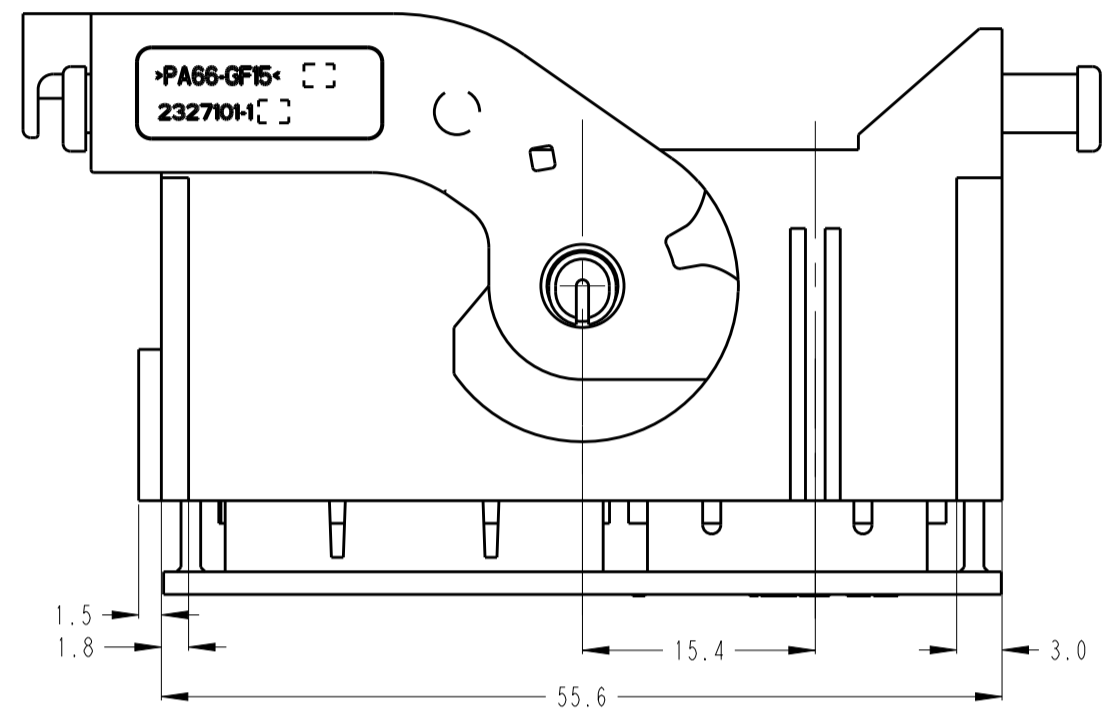
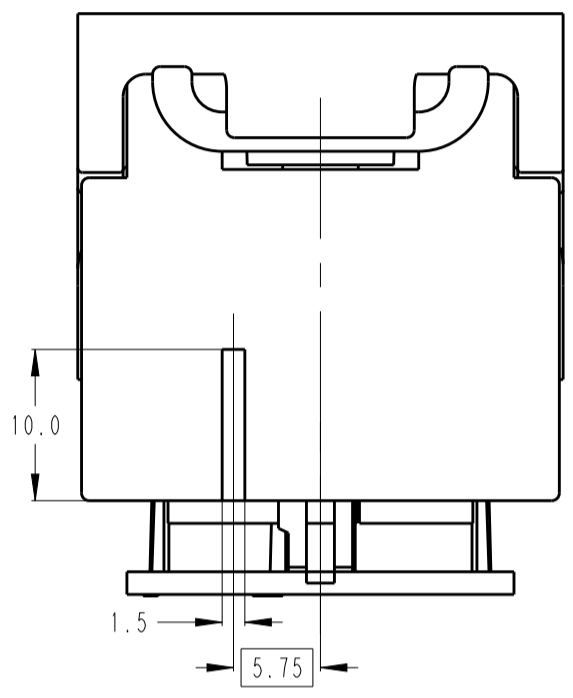
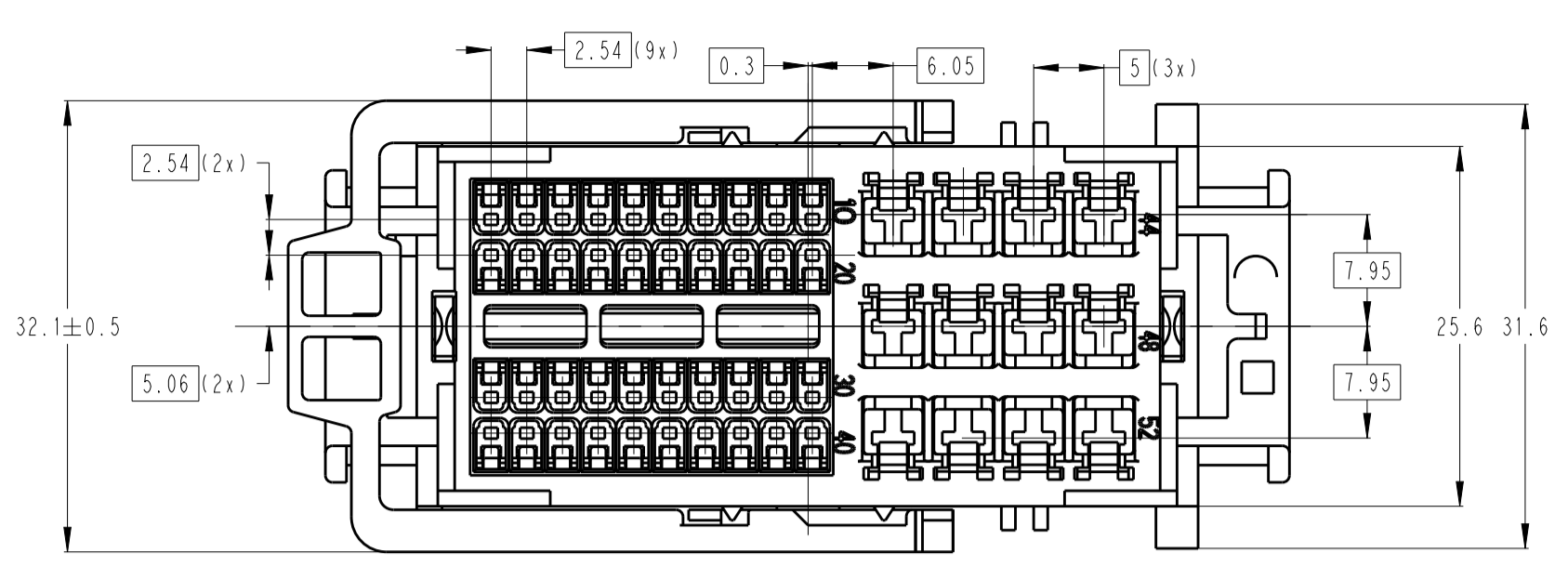
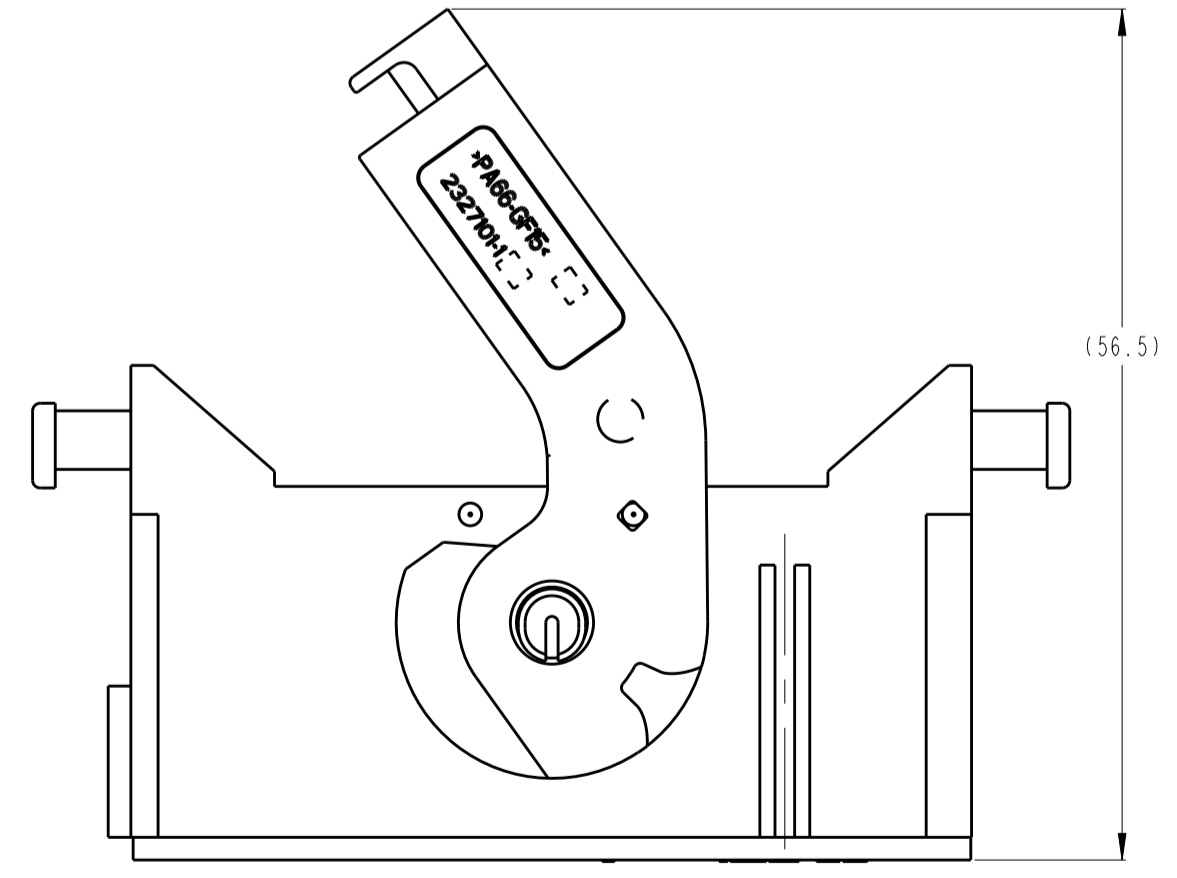

INSTALLATION CONFIGURATION

NOTES:

- TE ASSY P/N:2327104-X, X IS EXCHANGABLE, SEE TABLE.
- CONDITION AS SUPPLIED: SHIPPING CONFIGURATION (TPA IN THE PRE-LOCKED POSITION)
- MATING HEADER ASSY P/N: *-2098978-* OR REFER TO INTERFACE: 114-32367
- APPLICABLE CONTACT AND WIRE SIZE SEE BELOW TABLE:

CONTACT TYPE	CONTACT P/N	WIRE SIZE (AWG)	INSULATION DIA (MM)
FEMALE, CONTACT 0.64MM	638551-3	18-20	1.32-2.13
RECEPTACLE 2.8MM, UNSEALED	1326030-2	18-20	1.4-2.06

- 2327104-1: WIRE EXITING FROM 2.8MM SIDE
 0/1-* -3/4: WIRE EXITING FROM 0.64MM SIDE

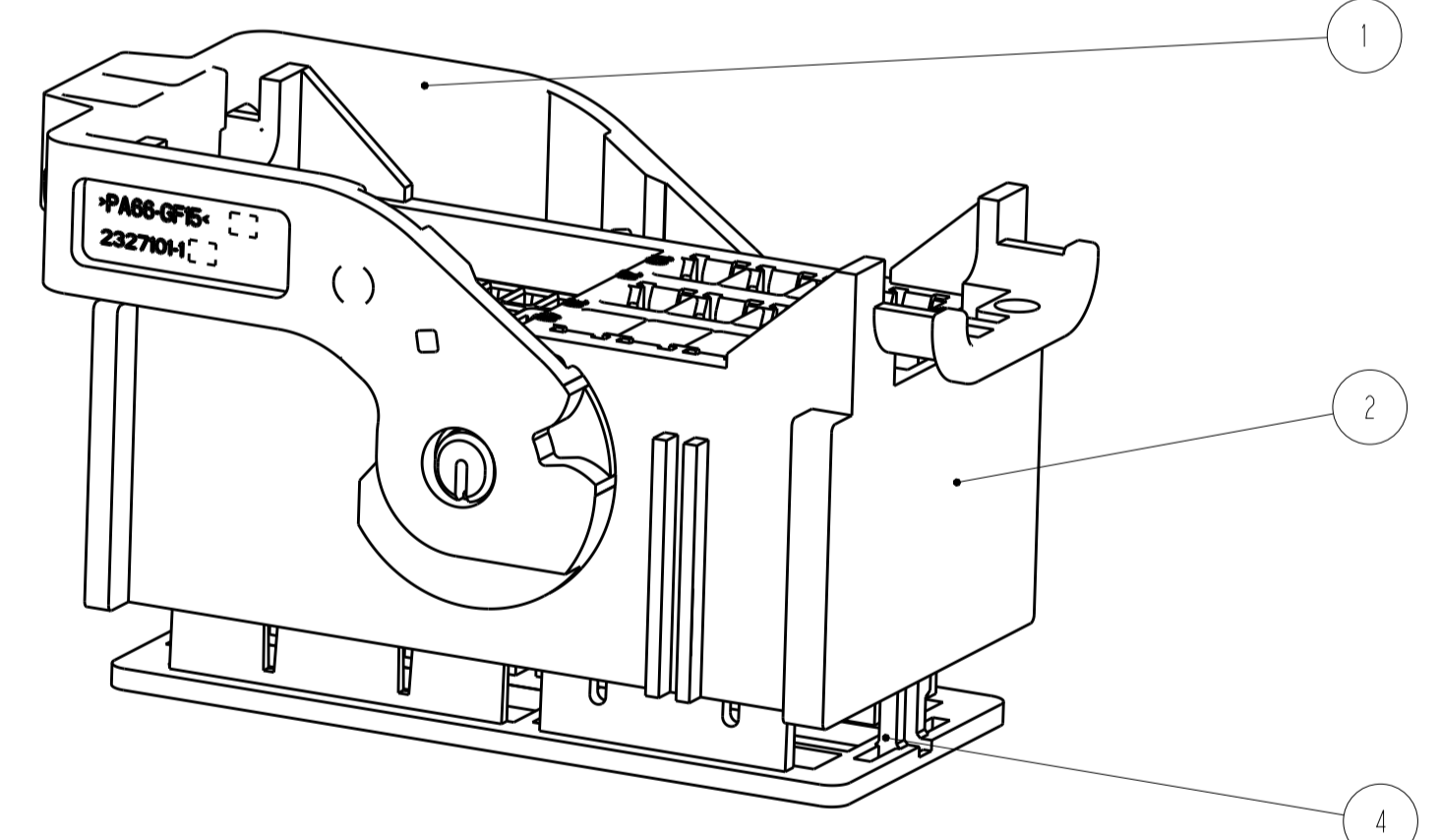

2327104-1

Q'TY	Q'TY	Q'TY	Q'TY	PART RAV.	PART P/N	COLOR	MATERIAL	DESCRIPTION	ITEM
1	-	-	-	A	2327101-3	BLACK	PA66-GF15	LEVER, 52 POSITION, TYPE 3	5
1	1	1	1	A	2327103-1	RED	PBT-GF15	TPA, 52 POSITION	4
-	-	1	-	A	2327100-3	BLACK	PA66-GF35	PLUG HSG, 52 POSITION	3
1	1	-	1	A	2327100-1	BLACK	PA66-GF35	PLUG HSG, 52 POSITION	2
-	1	1	1	A	2327101-1	BLACK	PA66-GF15	LEVER, 52 POSITION	1
A	A	A	A	ASSY RAV.					
1-* -4	*-4	*-3	*-1	ASSY P/N					

THIS DRAWING IS A CONTROLLED DOCUMENT. DIMENSIONS: mm. TOLERANCES UNLESS OTHERWISE SPECIFIED: 0 PLC ±0.2, 2 PLC ±0.10, 3 PLC ±0.10, 4 PLC ±0.10, ANGLES ±0.5°. MATERIAL: SEE TABLE. FINISH: -.

OWN: Z.LI, 25OCT2017. CHK: S.Y. WANG, 25OCT2017. APVD: J.YIN, 25OCT2017.

NAME: PLUG ASSEMBLY, 52 POSITION, 2.8MM AND 0.64MM TERMINAL. SIZE: A1. CAGE CODE: 00779. DRAWING NO: 2327104. RESTRICTED TO: -.

SCALE: 2:1. SHEET: 1 OF 2. REV: A2.

REVISIONS				
P.	LTN	DESCRIPTION	DATE	APVD
-	-	SEE SHEET 1	-	-

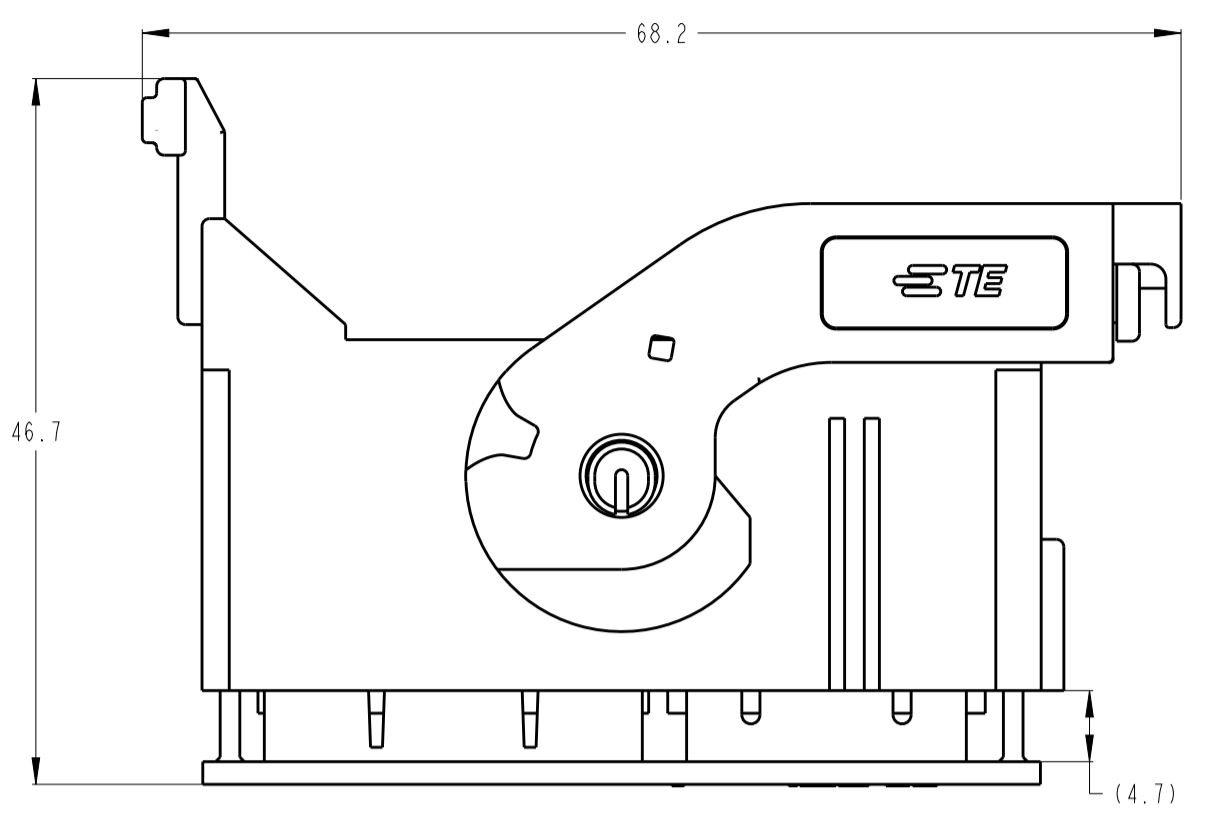

SHIPMENT CONFIGURATION

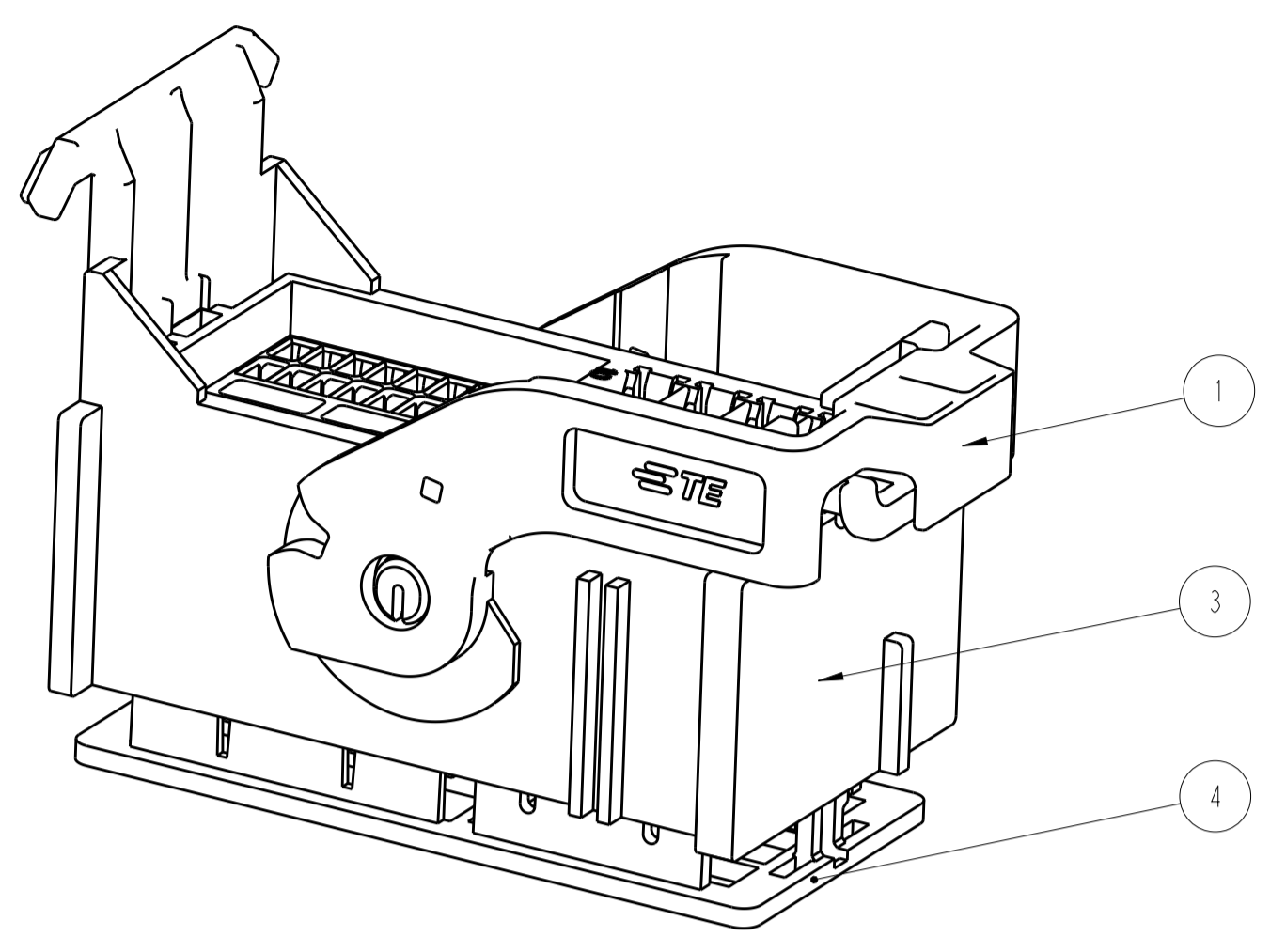

2327104-3

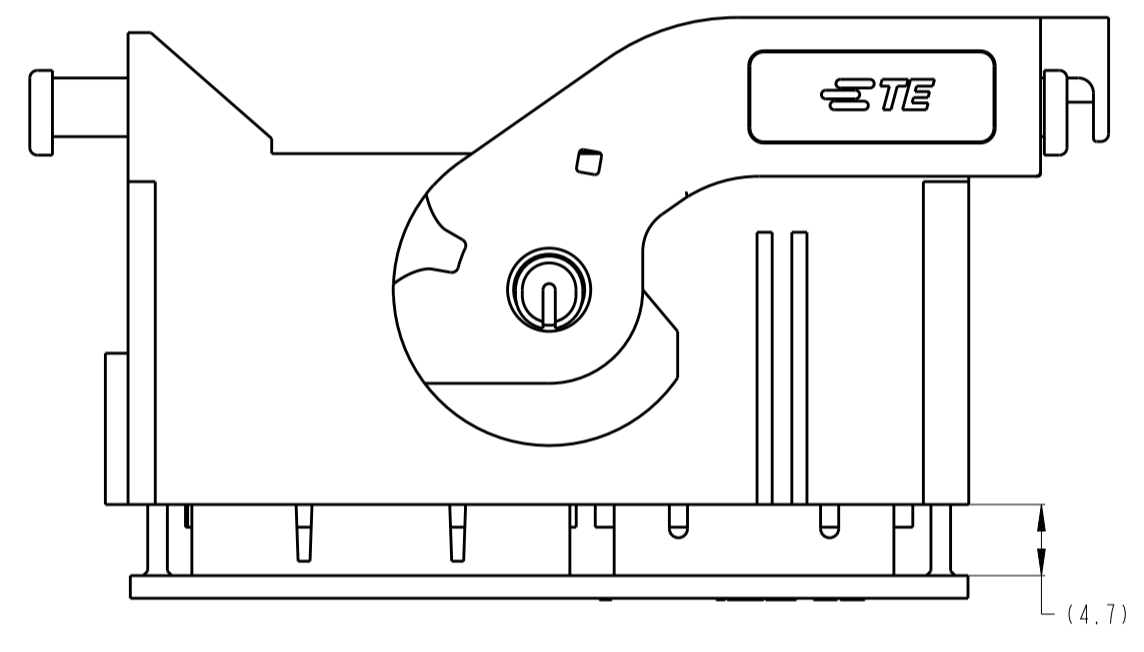

SHIPMENT CONFIGURATION

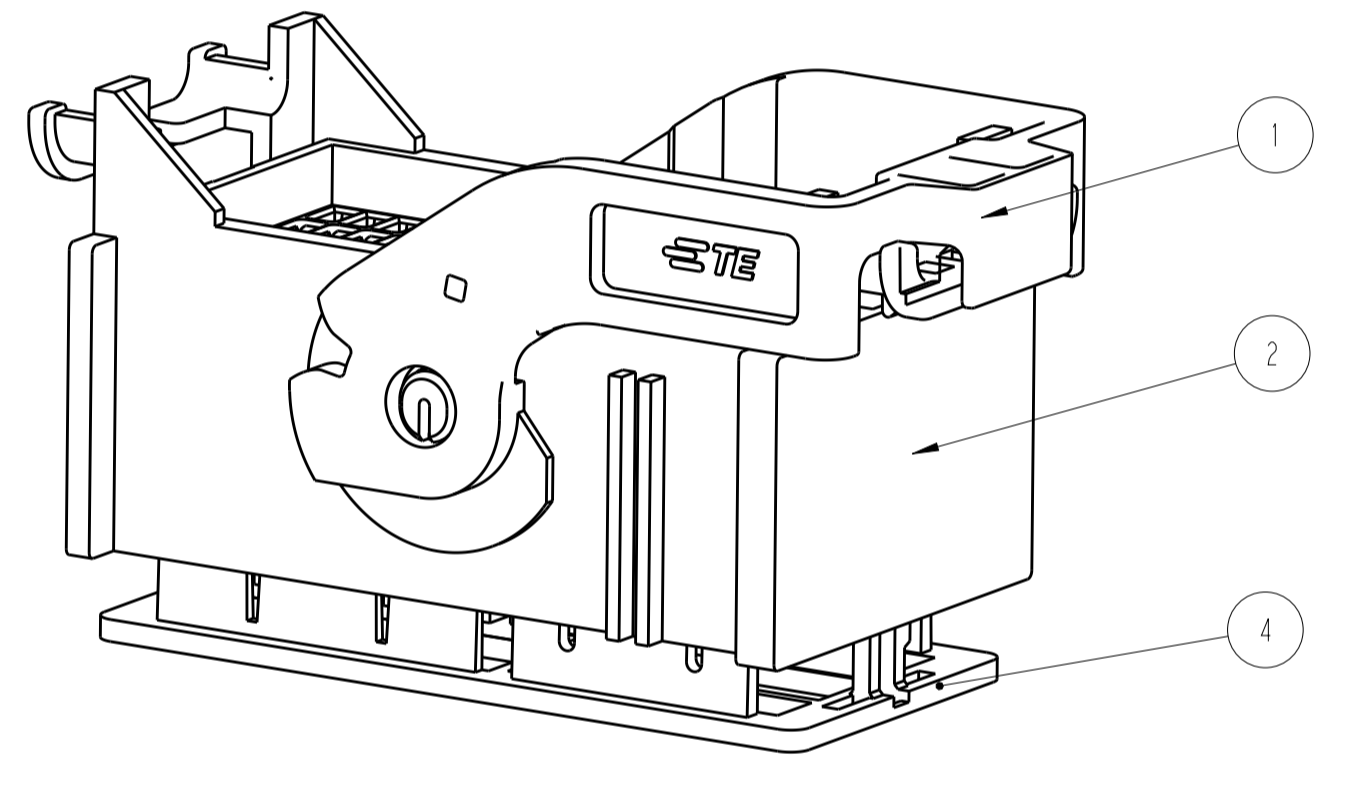

2327104-4

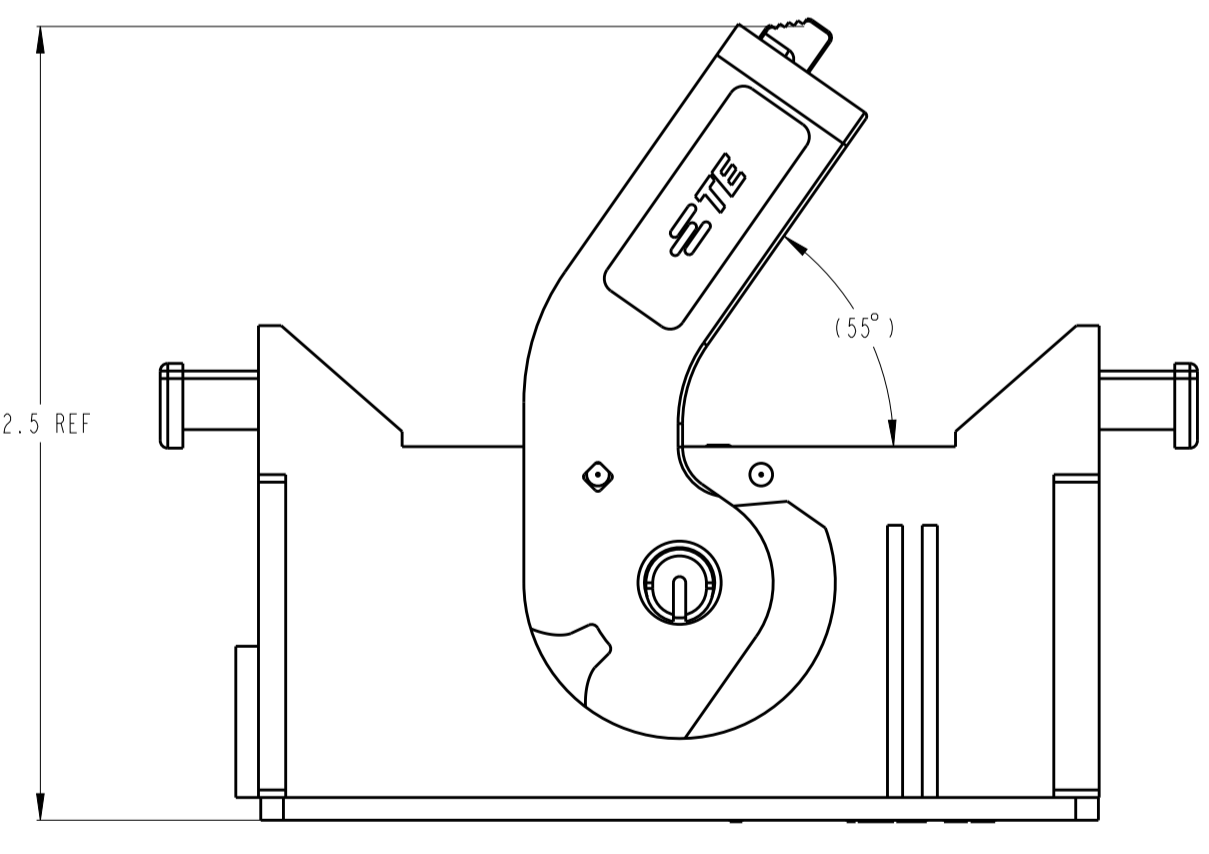

INSTALLATION CONFIGURATION
(TPA IN ENDOCK POSITION, LEVER IN PRELOCK POSITION)

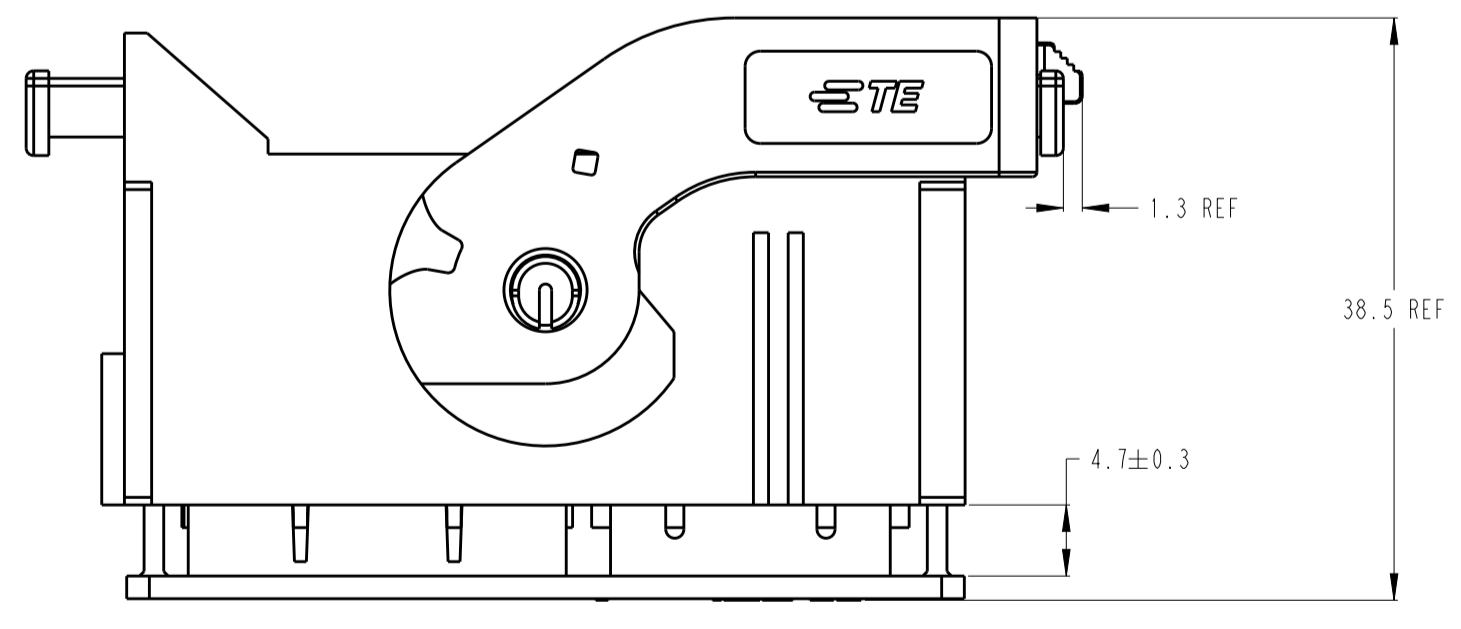

SHIPMENT CONFIGURATION
(TPA IN PRELOCK POSITION, LEVER IN ENDOCK POSITION)

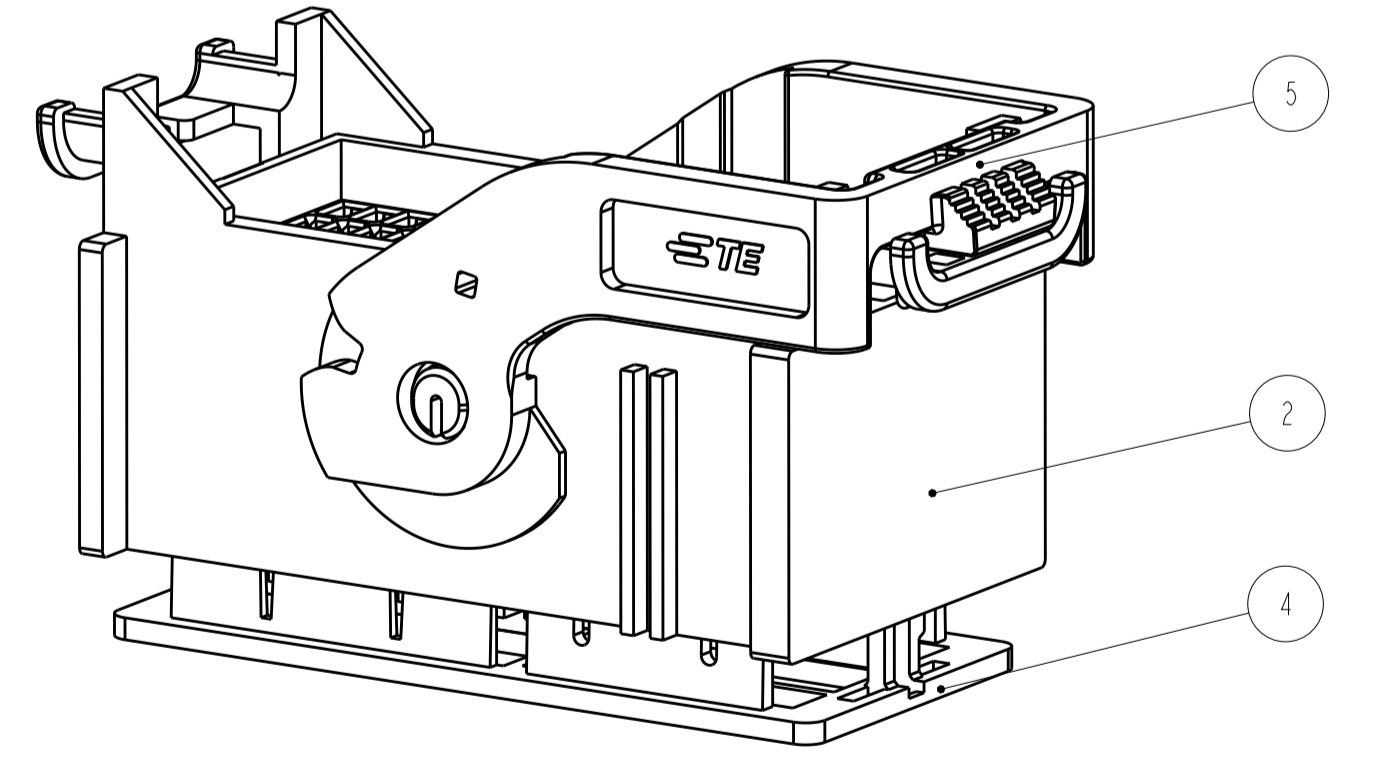

1-2327104-4

THIS DRAWING IS A CONTROLLED DOCUMENT.		DWN: Z.LI 25OCT2017	TE Connectivity
DIMENSIONS: mm		CHK: S.Y. WANG 25OCT2017	
TOLERANCES UNLESS OTHERWISE SPECIFIED:		APVD: J.YIN 25OCT2017	NAME: PLUG ASSEMBLY, 52 POSITION, 2.8MM AND 0.64MM TERMINAL
0 PLC ±	1 PLC ±0.2	PRODUCT SPEC	SIZE: A1
2 PLC ±0.10	3 PLC ±	APPLICATION SPEC	CAGE CODE: 00779
4 PLC ±	ANGLES ±	WEIGHT	DRAWING NO: 2327104
MATERIAL: SEE TABLE	FINISH	CUSTOMER DRAWING	SCALE: 2:1
SHEET 2 OF 2			REV: A2